

**XFP-1040-WA/WB**  
10Gbps XFP Bi-Directional Transceiver, 40km Reach  
1270/1330nm Tx / 1330/1270 nm Rx

### Features

- ◆ Supports 9.95Gb/s to 10.3Gb/s data rates
- ◆ Hot-pluggable XFP footprint
- ◆ Maximum link length of 40km with SMF
- ◆ 1270/1330nm DFB laser Transmitter and 1330/1270nm Receiver
- ◆ XFP MSA package with LC connector
- ◆ No reference clock required
- ◆ Loop Back Support.
- ◆ +3.3V, +1.8V power supply
- ◆ Power dissipation <2W
- ◆ Compatible with RoHS
- ◆ Built-in digital diagnostic functions
- ◆ Temperature range 0°C to 70°C



### Applications

- ◆ 10GBASE-ER 10G Ethernet at 10.3125Gbps
- ◆ 10GBASE-EW 10G Ethernet at 9.953Gbps
- ◆ 1200-SM-LL-L 1-0G Fiber Channel at 10.51875Gbps

### Description

The XFP-1040-WA/WB is compliant with the IEEE803.3ae 10Gbase-Bx. and transmission distance up to 40km on SMF. The transceiver module comprises a transmitter with a 1270/1330nm DFB laser transmitter, an integrated 1330/1270nm detector pre-amplifier(IDP) mounted in an optical header and a limiting post-amplifier IC. Transmitter and receiver are separate within a wide temperature range of 0°C to +70°C and offers optimum heat dissipation and excellent electromagnetic shielding thus enabling high port densities for 10 GbE systems.

## Absolute Maximum Ratings

Parameter	Symbol	Min	Max	Unit	Ref.
Storage Ambient Temperature Range		-40	+85	°C	
Powered case Temperature Range		0	+70	°C	
Operating Relative Humidity	RH		85	%	
Supply Voltage Range @3.3V	Vcc3	0	3.6	V	
Supply Voltage Range @ 1.8V		0	1.98	V	

Any stress beyond the maximum ratings can result in permanent damage. The device specifications are guaranteed only under the recommended operating conditions.

## Electrical Characteristics

Parameter	Symbol	Min	Typ	Max	Unit	Note
Operating Case Temperature Range	$T_c$	0		+70	°C	
Power Supply Voltage @ 3.3V	Vcc3	3.13	3.3	3.47	V	
Power Supply Voltage @ 1.8V		1.62	1.8	1.98		
Module total power	P			2	W	
<b>Transmitter</b>						
Input differential impedance	Rin		100		$\Omega$	1
Differential data input swing	Vin,pp	120		820	mV	
Transmit Disable Voltage	VD	2.0		VCC	V	
Transmit Enable Voltage	VEN	0		0.8	V	
Transmit Disable Assert Time				10	us	
<b>Receiver</b>						
Differential data output swing	Vout,pp	340		850	mV	
Data output rise time	$t_r$			38	ps	2
Data output fall time	$t_f$			38	ps	2
LOS Fault	V <sub>LOS fault</sub>	VCC – 0.5		VCC <sub>HOST</sub>	V	3
LOS Normal	V <sub>LOS norm</sub>	GND		GND+0.5	V	3
Power Supply Rejection	PSR		See Note 3 below			4

### Notes:

1. After internal AC coupling.
2. 20 – 80 %
3. Loss Of Signal is open collector to be pulled up with a 4.7k – 10kohm resistor to 3.15 – 3.6V. Logic 0 indicates normal operation; logic 1 indicates no signal detected.
4. Per Section 2.7.1. in the XFP MSA Specification.

## Optical Characteristics

Parameter	Symbol	Min	Typ	Max	Unit	Ref.	
<b>Transmitter</b>							
Optical output Power	P	0		4	dBm		
Optical Wavelength	$\lambda$	1260	1270	1280	nm		
		1320	1330	1340			
Side Mode Suppression Ratio	SMSR	30			dB		
Optical Extinction Ratio	ER	3.5			dB	1	
Average Launch power of OFF transmitter	POFF	-30			dBm		
Tx Jitter	Tx <sub>j</sub>	Compliant with each standard requirements					
<b>Receiver</b>							
Receiver Sensitivity	RSENS			-14	dBm	2	
Receiver Sensitivity in OMA	RSENS			-12.5	dBm	2	
Maximum Input Power	P <sub>MAX</sub>	0.5			dBm		
Optical Center Wavelength	$\lambda_C$	1320		1340	nm		
		1260		1280			
LOS De-Assert	LOS <sub>D</sub>			-18	dBm		
LOS Assert	LOS <sub>A</sub>	-30			dBm		
LOS Hysteresis		1		5	dB		

Notes:

1, PRBS 2<sup>31</sup>-1 test pattern @10.3125Gbps.

2, PRBS 2<sup>31</sup>-1 test pattern @10.3125Gbps, BER≤10<sup>-12</sup>.

## Pin Descriptions

Pin	Logic	Symbol	Name/Description	Ref
1		GND	Module Ground	1
2		VEE5	Optional -5.2 Power Supply – <b>Not required</b>	
3	LVTTTL-I	Mod-Desel	Module De-select; When held low allows the module to respond to 2-wire serial interface commands	
4	LVTTTL-O	Interrupt	Interrupt (bar); Indicates presence of an important condition which can be read over the serial 2-wire interface	2
5	LVTTTL-I	TX_DIS	Transmitter Disable; Transmitter laser source turned off	
6		VCC5	+5 Power Supply– <b>Not required</b>	
7		GND	Module Ground	1

8		VCC3	+3.3V Power Supply	
9		VCC3	+3.3V Power Supply	
10	LVTTTL-I	SCL	Serial 2-wire interface clock	2
11	LVTTTL-I/O	SDA	Serial 2-wire interface data line	2
12	LVTTTL-O	Mod_Abs	Module Absent; Indicates module is not present. Grounded in the module.	2
13	LVTTTL-O	Mod_NR	Module Not Ready;	2
14	LVTTTL-O	RX_LOS	Receiver Loss of Signal indicator	2
15		GND	Module Ground	1
16		GND	Module Ground	1
17	CML-O	RD-	Receiver inverted data output	
18	CML-O	RD+	Receiver non-inverted data output	
19		GND	Module Ground	1
20		VCC2	+1.8V Power Supply	
21	LVTTTL-I	P_Down/RS	Power Down; When high, places the module in the low power stand-by mode and on the falling edge of P_Down initiates a module reset Reset; The falling edge initiates a complete reset of the module including the 2-wire serial interface, equivalent to a power cycle.	
22		VCC2	+1.8V Power Supply	
23		GND	Module Ground	1
24	PECL-I	RefCLK+	Reference Clock non-inverted input, AC coupled on the host board – <b>Not required</b>	3
25	PECL-I	RefCLK-	Reference Clock inverted input, AC coupled on the host board – <b>Not required</b>	3
26		GND	Module Ground	1
27		GND	Module Ground	1
28	CML-I	TD-	Transmitter inverted data input	
29	CML-I	TD+	Transmitter non-inverted data input	
30		GND	Module Ground	1

**Notes:**

1. Module circuit ground is isolated from module chassis ground within the module.
2. Open collector; should be pulled up with 4.7k – 10k ohms on host board to a voltage between 3.15V and 3.6V.
3. A Reference Clock input is not required.

## Hostboard Connector Pinout

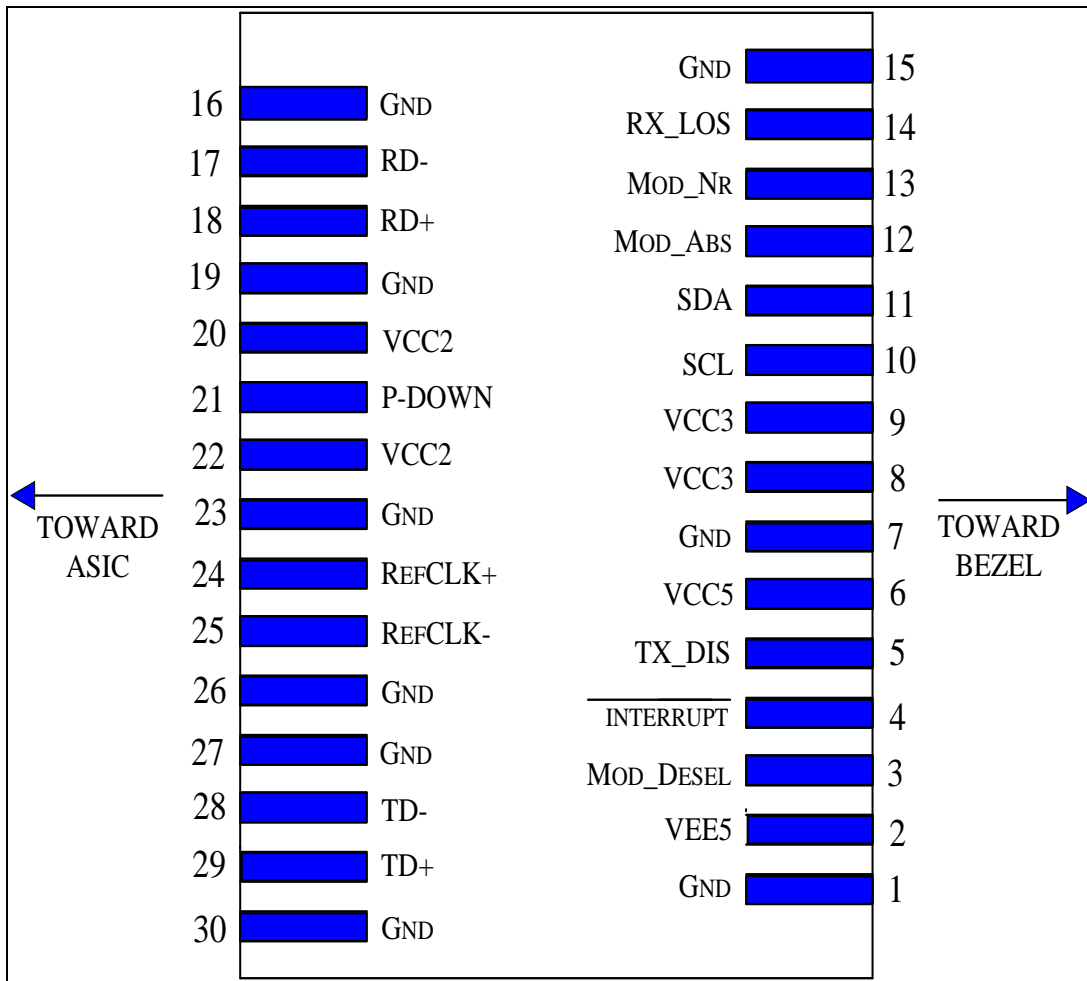

## General Specifications

Parameter	Symbol	Min	Typ	Max	Units	Ref.
Bit Rate	BR	9.95		10.5	Gb/s	1
Bit Error Ratio	BER			$10^{-12}$		2
Max. Supported Link Length	L <sub>MAX</sub>		40		km	1

**Notes:**

1. Tested with a  $2^{31} - 1$  PRBS

## Management Interface

The transceivers provide serial ID memory contents and diagnostic information about the present operating conditions by the 2-wire serial interface (SCL, SDA).

The Module provides diagnostic information about the present operating conditions. The transceiver generates this diagnostic data by digitization of internal analog signals. Alarm/warning threshold data is written during device manufacture. Received power monitoring, transmitted power monitoring, bias current monitoring, supply voltage monitoring and temperature monitoring all are implemented.

The digital diagnostic memory map specific data field defines as following.

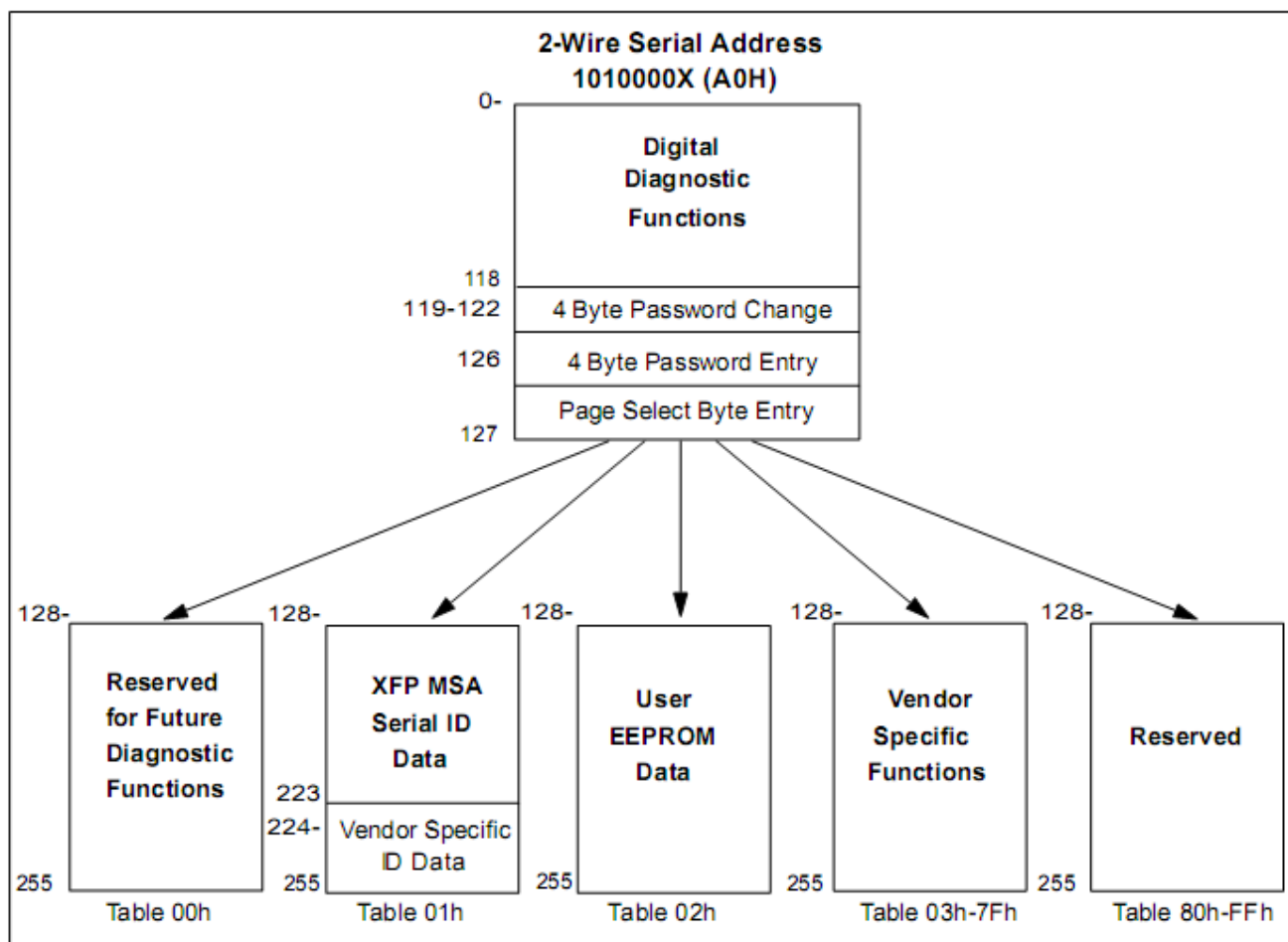

### Recommended Host Board Power Supply Circuit

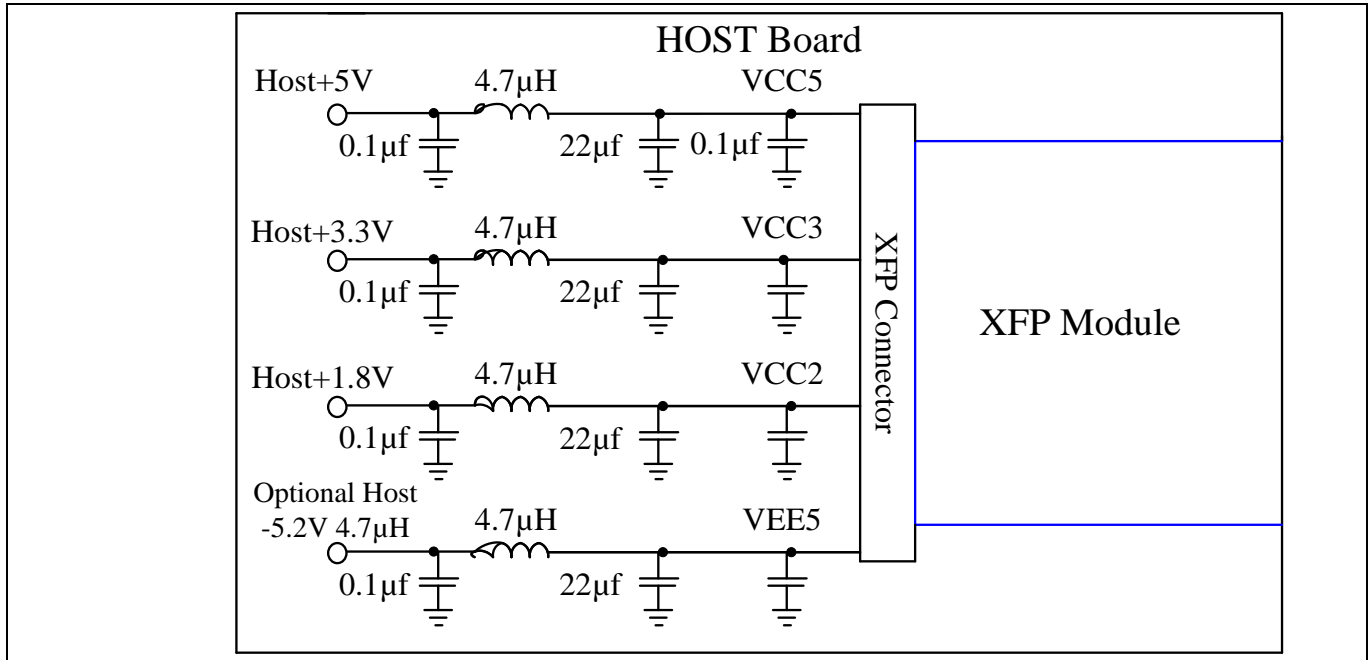

### Recommended High-speed Interface Circuit

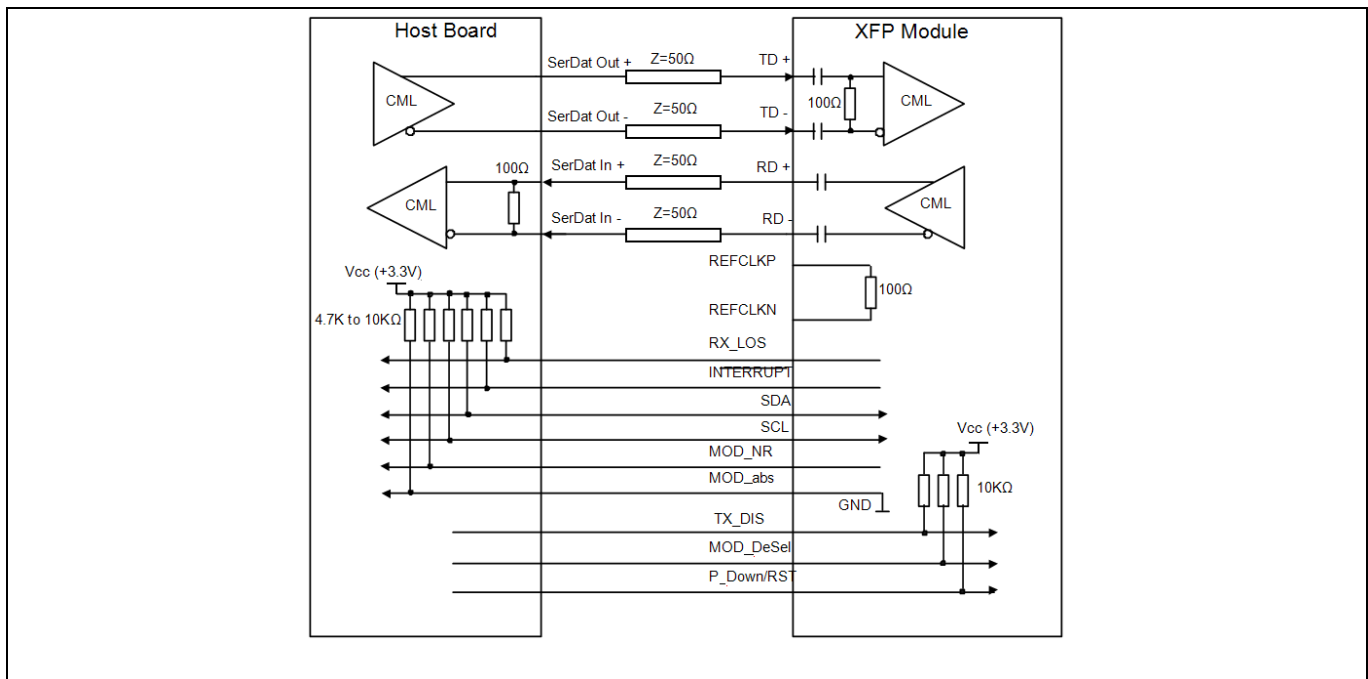

## Mechanical Specifications

XFP transceivers are compliant with the dimensions defined by the XFP Multi-Sourcing Agreement (MSA).

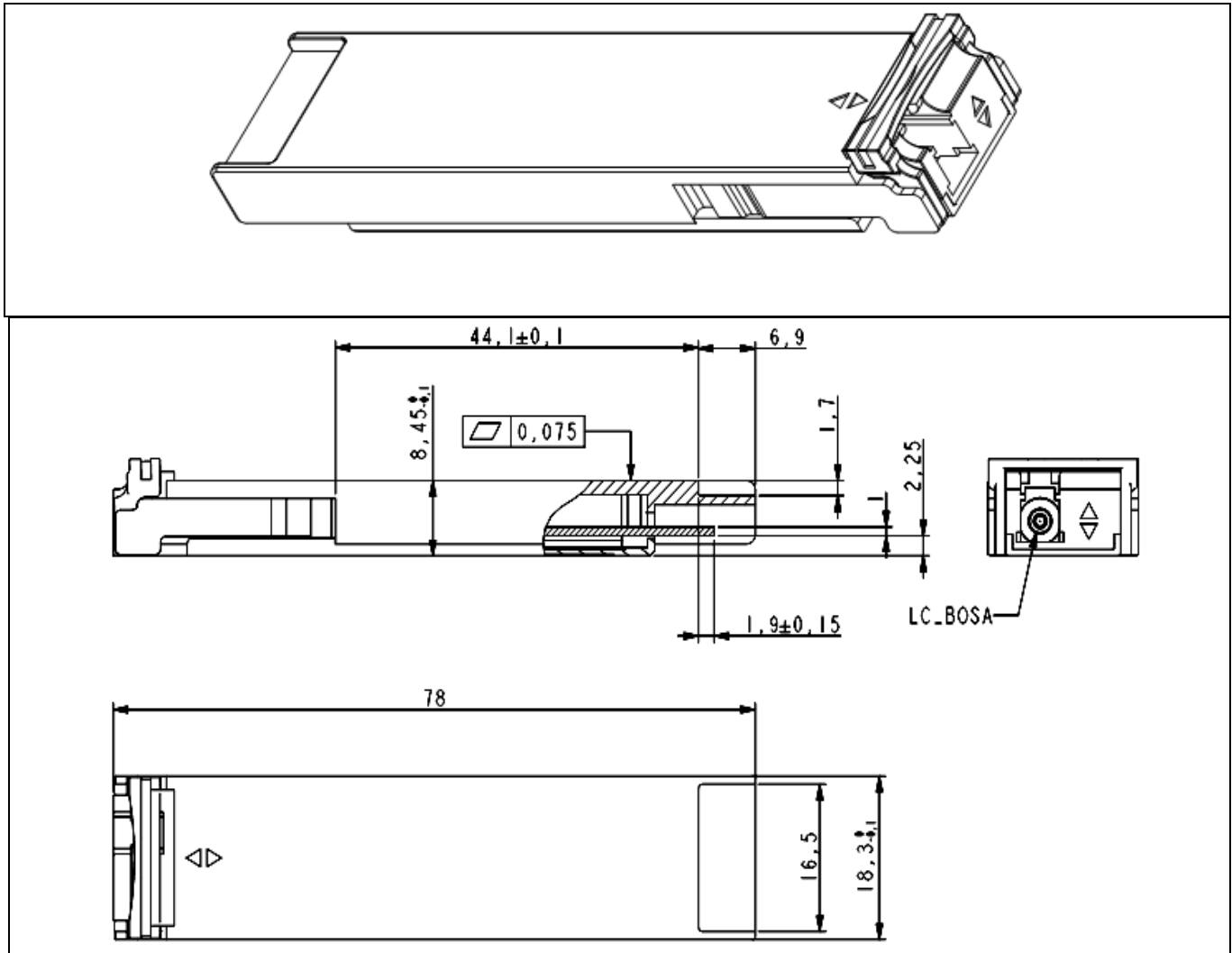

## Ordering information

Part Number	Product Description
XFP-1040-WA	1270nm DFB laser Transmitter and 1330nm Receiver, 10Gbps, 40km, 0°C ~ +70°C
XFP-1040-WB	1330nm DFB laser Transmitter and 1270nm Receiver, 10Gbps, 40km, 0°C ~ +70°C

E-mail: [sales@robofiber.com](mailto:sales@robofiber.com)