

---

## XFP Optical Transceiver, 300m Reach

### XFP-1000-SR

#### Features

- ◆ Supports 9.95Gbps to 11.1Gbps bit rates
- ◆ Maximum link length of 300m (50um,MMF,2000MHz.Km)
- ◆ 850nm VCSEL laser and PIN receiver
- ◆ XFP MSA Rev 4.5 Compliant
- ◆ No reference clock required
- ◆ +1.8V,+3.3V Supply Voltage
- ◆ Low Power Dissipation 1.5W Maximum
- ◆ XFI and lineside loopback Mode Supported
- ◆ 0°C to 70°C Operating Case Temperature
- ◆ Diagnostic Performance Monitoring of module temperature, Supply Voltages, laser bias current, transmit optical power, and receive optical power
- ◆ RoHS6 compliant (lead free) 



#### Applications

- ◆ 10GBASE-SR/SW 10G Ethernet
- ◆ 1200-Mx-SN-I 10G Fiber Channel
- ◆ Other optical links

#### Description

The XFP-1000-SR is compliant with the 10G Small Form-Factor Pluggable (XFP) Multi-Source Agreement (MSA), supporting data-rate of 10.3125Gbps(10GBASE-SR) or 9.953Gbps (10GBASE-SW), and transmission distance up to 300m on 50µm MMF (2000MHz.km).

The transceiver module comprises a transmitter with 850nm a vertical cavity surface emitting (VCSEL) laser and a receiver with a PIN photodiode. Transmitter and receiver are separate within a wide temperature range of 0°C to +70°C and offers optimum heat dissipation and excellent electromagnetic shielding thus enabling high port densities for 10G systems.

## Absolute Maximum Ratings

Parameter	Symbol	Min	Max	Unit
Storage Temperature	$T_{st}$	-40	+85	°C
Case Operating Temperature	$T_{op}$	0	+70	°C
Operating Relative Humidity	$RH$		85	%
Supply Voltage 1	$V_{cc3.3}$	-0.5	3.6	V
Supply Voltage 2	$V_{cc1.8}$	-0.5	1.98	V

## Operating Conditions

Parameter	Symbol	Min	Typical	Max	Unit
Supply Voltage 1	$V_{cc3}$	3.13	3.3	3.47	V
Supply current 1	$I_{cc3}$	-	-	300	mA
Supply Voltage 2	$V_{cc2}$	1.71	1.8	1.89	V
Supply current 2	$I_{cc2}$	-	-	150	mA
Operating Case temperature	$T_{ca}$	-5	-	70	°C
Module Power Dissipation	$P_m$	-	-	1.5	W

## Electrical Transmitter

Parameter	Symbol	Min	Typ	Max	Units	Ref.
Input Differential Impedance	$R_{IND}$	-	100	-	$\Omega$	1
Differential input Voltage Swing	$V_{ID}$	120	-	1000	mV	2
Transmit Disable Voltage	$V_{Dis}$	2.0	-	VCC		
Transmit Enable Voltage	$V_{EN}$	GND	-	GND+0.8		
Transmit Disable Assert Time		-	-	10	us	

### Notes:

1. after internal AC coupling.
2. Beneath this level the signal can't meet the specification

## Electrical Receiver

Parameter	Symbol	Min	Typ	Max	Units	Ref.
Differential Output Impedance	$Z_{OD}$		100		$\Omega$	
Differential Output Amplitude	$V_{OSPP}$	500		800	mV	1
Transition Time Low to High	$t_r$	40			ps	2
Transition Time High to Low	$t_f$	40			ps	2
LOS Fault	$L_{fault}$	Vcc-0.5		VCCHOST	V	3
LOS Normal	$L_{normal}$	GND		GND+0.5	V	3

### Notes:

1. Into 100 ohms differential termination.
2. 20 – 80 %.
3. Loss Of Signal is open collector to be pulled up with a 4.7k  $\Omega$  – 10k  $\Omega$  resistor to 3.15 – 3.6V. Logic 0, indicates normal operation; logic 1 indicates no signal detected.

## Optical Transmitter

Parameter	Symbol	Min	Typ	Max	Units	Ref.	
Nominal Wavelength	$\lambda_{TRP}$	840	850	860	nm		
RMS Spectral Width	$\Delta\lambda$		0.4	0.45	nm		
Average Power	$P_{optavg}$	-7.3		-1	dBm	1	
Launch power in OMA	OMA	-2.8	-1.5		dBm		
Extinction Ratio	ER	3.5			dB	2	
Tx Jitter	TXJ	Per 802.3ae requirements					
Relative Intensity Noise	RIN			-128	dB/Hz		
Transmitter and Dispersion Penalty	TDP			3.9	dB		

### Notes:

1. Launched into MMF.
2. Measured with PRBS  $2^{31}-1$  @10.3125Gbps.

## Optical Receiver

Parameter	Symbol	Min	Typ	Max	Units	Ref.
Center Wavelength	$\lambda_c$	840	850	860	Nm	
Receiver Sensitivity	$P_{IN}$			-11	dBm	1
Receiver Sensitivity in OMA	$P_{IN}$			-11.1	dBm	1
Stressed receiver sensitivity in OMA	$P_{IN}$			-7.5	dBm	1
Receiver Overload	$P_{in}$	-1.0		+1	dBm	1
Receiver Reflectance				-12	dBm	
LOS De-Assert	LOSD			-12	dBm	
LOS Assert	LOSA	-25	-15		dBm	
LOS Hysteresis	LOSH	0.5			dB	

### Notes:

1. Measured with PRBS  $2^{31}-1$  @10.3125Gbps.

## General Specifications

Parameter	Conditions	Min Modal Bandwidth (MHz*Km)	Symbol	Min	Typ	Max	Units	Ref.
Operating Range	62.5/125 $\mu$ m MMF	160	$I_{OP}$	2		26	m	
	50/125 $\mu$ m MMF	400				66		
	62.5/125 $\mu$ m MMF	200				33		
	50/125 $\mu$ m MMF	500				82		
	50/125 $\mu$ m MMF	2000				300		
Bit Rate			BR	9.95		11.1	Gbps	1
Bit Error Ratio			BER			$10^{-12}$		2

### Notes:

1. 10GBASE-SR/SW, 1200-Mx-SN-I
2. Measured with PRBS  $2^{31}-1$

## Pin Descriptions

Pin	Logic	Symbol	Name/Description	Ref
1		GND	Module Ground	1
2		VEE5	Optional –5.2 Power Supply – <b>Not required</b>	
3	LVTTL-I	Mod-Desel	Module De-select; When held low allows the module to respond to 2-wire serial interface commands	
4	LVTTL-O	Interrupt	Interrupt (bar); Indicates presence of an important condition which can be read over the serial 2-wire interface	2
5	LVTTL-I	TX_DIS	Transmitter Disable; Transmitter laser source turned off	
6		VCC5	+5 Power Supply – <b>Not required</b>	
7		GND	Module Ground	1
8		VCC3	+3.3V Power Supply	
9		VCC3	+3.3V Power Supply	
10	LVTTL-I	SCL	Serial 2-wire interface clock	2
11	LVTTL- I/O	SDA	Serial 2-wire interface data line	2
12	LVTTL-O	Mod_Abs	Module Absent; Indicates module is not present. Grounded in the module.	2
13	LVTTL-O	Mod_NR	Module Not Ready;	2
14	LVTTL-O	RX_LOS	Receiver Loss of Signal indicator	2
15		GND	Module Ground	1
16		GND	Module Ground	1
17	CML-O	RD-	Receiver inverted data output	
18	CML-O	RD+	Receiver non-inverted data output	
19		GND	Module Ground	1
20		VCC2	+1.8V Power Supply	
21	LVTTL-I	P_Down/RST	Power Down; When high, places the module in the low power stand-by mode and on the falling edge of P_Down initiates a module reset	
			Reset; The falling edge initiates a complete reset of the module including the 2-wire serial interface, equivalent to a power cycle.	
22		VCC2	+1.8V Power Supply	
23		GND	Module Ground	1
24	PECL-I	RefCLK+	Reference Clock non-inverted input, AC coupled on the host board – <b>Not required</b>	3
25	PECL-I	RefCLK-	Reference Clock inverted input, AC coupled on the host board – <b>Not required</b>	3
26		GND	Module Ground	1
27		GND	Module Ground	1
28	CML-I	TD-	Transmitter inverted data input	
29	CML-I	TD+	Transmitter non-inverted data input	
30		GND	Module Ground	1

### Notes:

1. Module circuit ground is isolated from module chassis ground within the module.
2. Open collector; should be pulled up with 4.7k – 10k ohms on host board to a voltage between 3.15V and 3.6V.
3. Reference Clock input is not required.

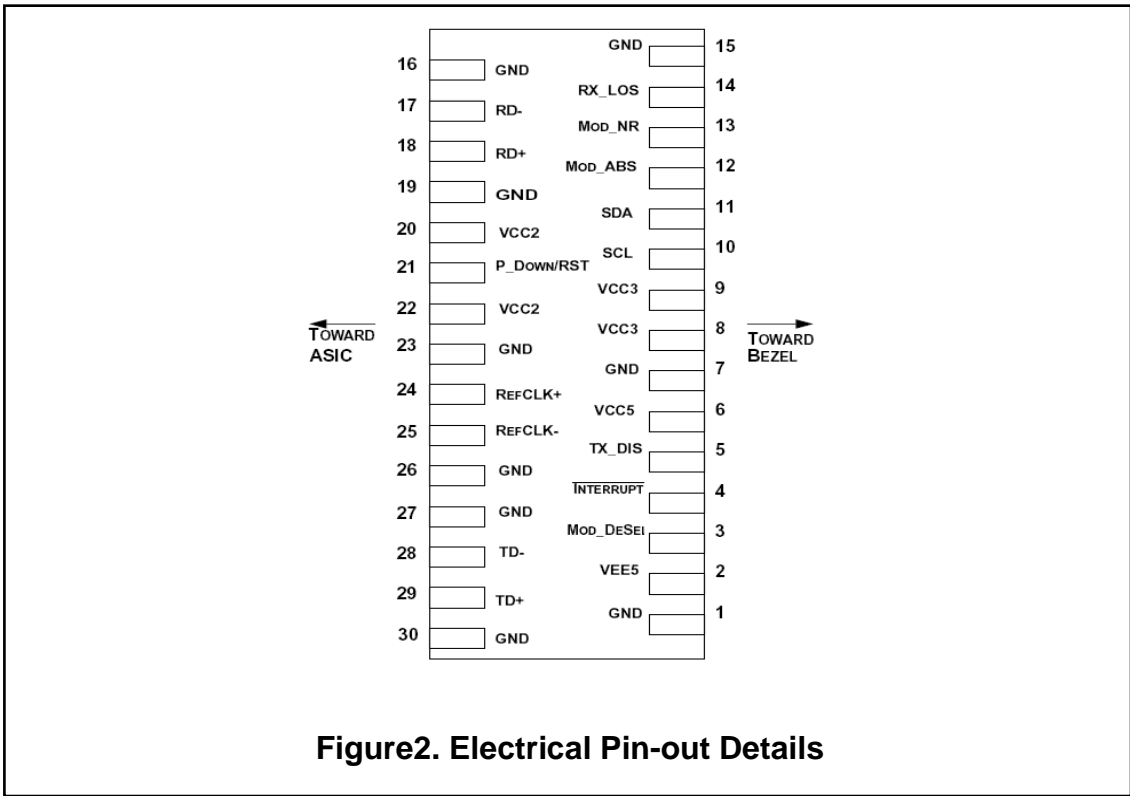

**Figure2. Electrical Pin-out Details**

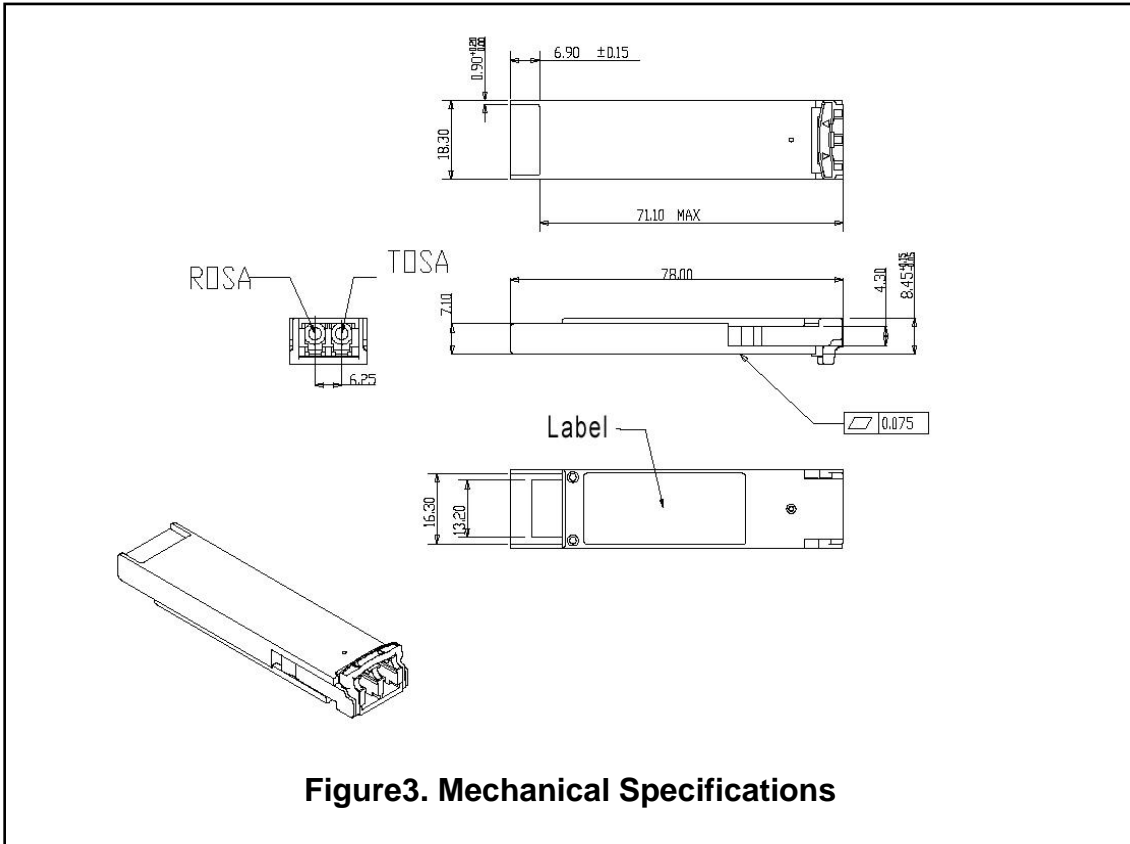

**Figure3. Mechanical Specifications**

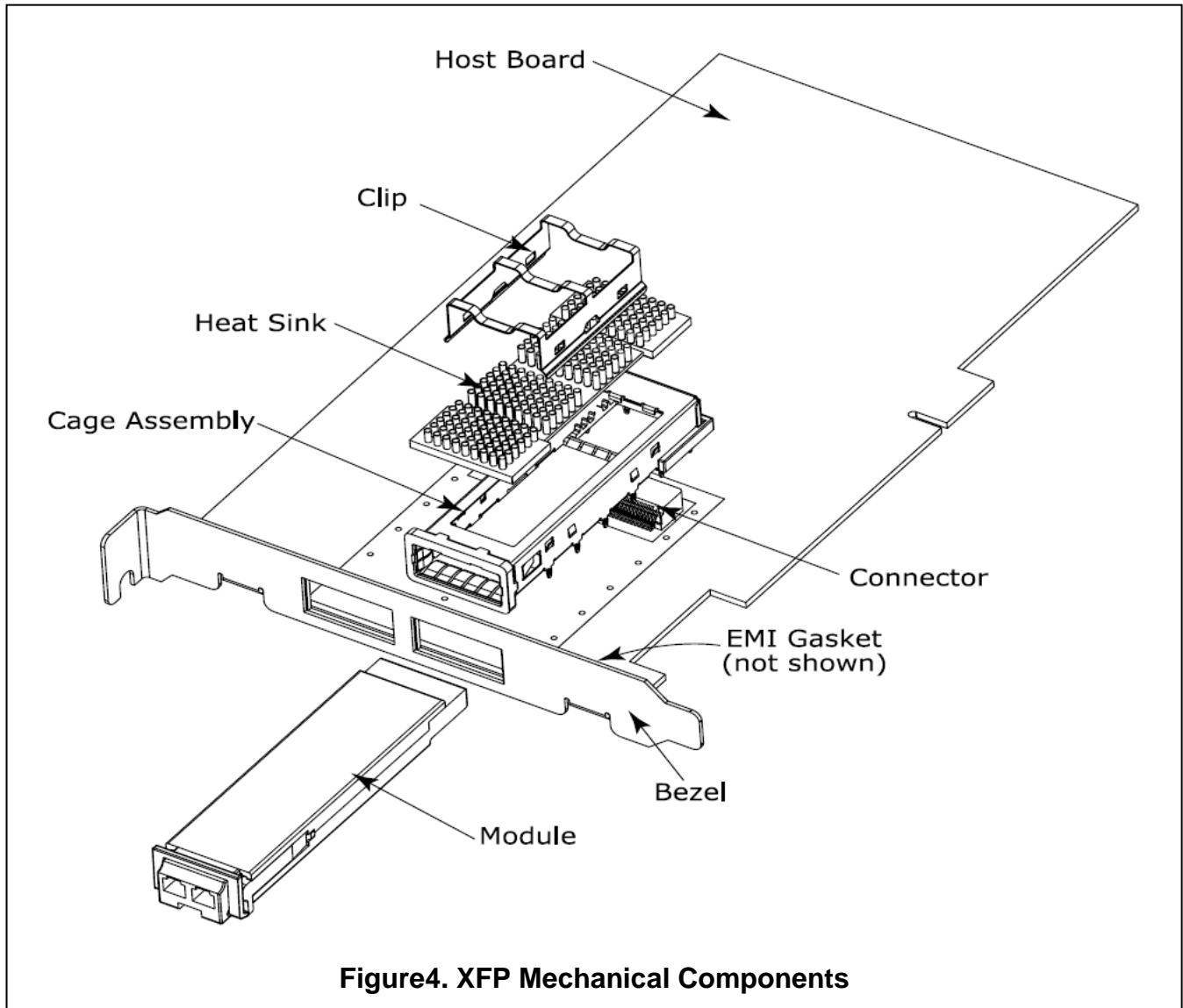

**The mechanical components defined:**

1. The module, clip and connector dimensions are constant for all applications. While the bezel, cage assembly, EMI gasket and heat sink can be designed and/or adjusted for the individual application.
2. The relatively small form factor of the XFP module combined with an adaptable heatsink option allows host system design optimization of module location, heatsink shape/dimension/fins design, and airflow control. The module can be inserted and removed from the cage with the heat sink and clip attached.

## Regulatory Compliance

XFP-1000-SR transceiver is designed to be Class I Laser safety compliant and is certified per the following standards:

Feature	Agency	Standard	Certificate / Comments
Laser Safety	FDA	CDRH 21 CFR 1040 and Laser Notice No. 50	1120288-000
Product Safety	UL	UL and CUL EN60950-2:2007	E347511
Environmental protection	SGS	RoHS Directive 2002/95/EC	GZ1001008706/CHEM
EMC	WALTEK	EN 55022:2006+A1:2007 EN 55024:1998+A1+A2:2003 -	WT10093768-D-E-E

## Ordering information

Part Number	Product Description
XFP-1000-SR	850nm VCSEL, 10Gbps, 300m, 0°C ~ +70°C

## References

1. 10 Gigabit Small Form Factor Pluggable Module (XFP) Multi-Source Agreement (MSA), Rev 4.5 – August 2005. Documentation is currently available at <http://www.xfpmsa.org/>
2. IEEE802.3ae – 2002
3. ITU-T G.709 / ITU-T G.959.1 <http://www.itu.int/>
4. Telcordia GR-253-CORE

E-mail: [sales@robofiber.com](mailto:sales@robofiber.com)