

Hybrid Passive Copper QSFP+ to 4xSFP+ QSFP-4SFP10-01C

Features

- ◆ Hybrid cable conforms to the Small Form Factor SFF-8436 and SFF-8431
- ◆ Support for multi-gigabit data rates :1.0 Gbps - 10.3125 Gbps (per channel)
- ◆ Maximum aggregate data rate: 41.25 Gbps (4 x 10.3125Gbit/s)
- ◆ Hybrid cable link length up to 5m (passive limiting)
- ◆ High-Density QSFP 38-PIN and 4x SFP 20-PIN Connector
- ◆ Power Supply :+3.3V
- ◆ Low power consumption: 0.02 W (typ.)
- ◆ Temperature Range: 0~ 70 °C

Applications

40G QSFP+ to 4x10SFP+

- ◆ 10G/40Gigabit Ethernet
- ◆ InfiniBand SDR, DDR, QDR
- ◆ Switches, Routers, and HBAs
- ◆ Data Centers
- ◆ Fiber Channel



Supported Standards

QSFP+

- ◆ SFF-8436
- ◆ QDR InfiniBand
- ◆ QSFP+ MSA
- ◆ RoHS Compliant

SFP+

- ◆ SFF-8431
- ◆ SFP+ MSA
- ◆ RoHS Compatible

Product Description

The QSFP+ to 4x SFP+ Passive cable assemblies are high performance, cost effective for SFP+ and QSFP+ equipment interconnections. The Hybrid cables are compliant with SFF-8436 and SFF-8431 specifications. They offer a low power consumption being ideal for short reach interconnect applications. Each cable lane is capable of transmitting data at rates up to 10Gb/s, providing an aggregated rate of 40Gb/s.

Recommended Operating Conditions

Parameter	Symbol	Min	Typical	Max	Unit
Storage Ambient Temperature		-40		+85	°C
Operating Case Temperature	T _c	0		+70	°C
Power Supply Voltage	V _{CC3}	3.14	3.3	3.47	V
Power Dissipation	PD			0.02	W

Mechanical Dimensions

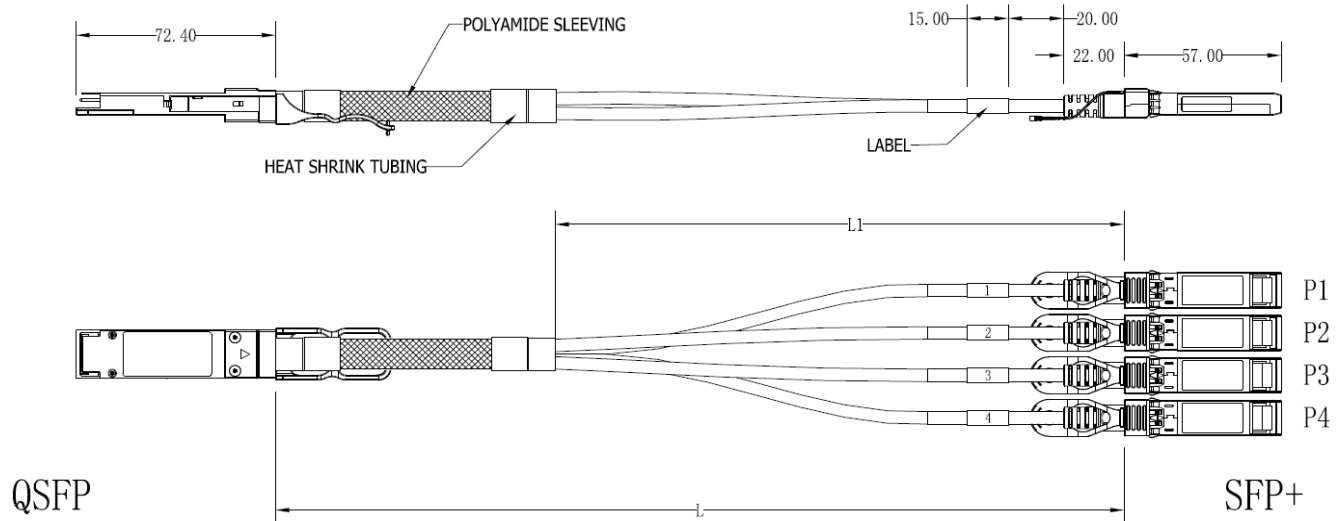

$L \leq 0.5$	+3/-3	$L1=4/5L$	+6/-6
$0.5 < L \leq 3$	+5/-5	$L1=4/5L$	+10/-10
$3 < L \leq 10$	+8/-8	$L1=4/5L$	+16/-16

QSFP+ Pin Descriptions

Pin	Logic	Symbol	Name/Description	Notes
1		GND	Ground	1
2	CML-I	Tx2n	Transmitter Inverted Data Input	
3	CML-I	Tx2p	Transmitter Non-Inverted Data Input	
4		GND	Ground	1
5	CML-I	Tx4n	Transmitter Inverted Data Input	
6	CML-I	Tx4p	Transmitter Non-Inverted Data Input	
7		GND	Ground	1
8	LVTTL-I	ModSelL	Module Select	
9	LVTTL-I	ResetL	Module Reset	
10		Vcc Rx	+3.3V Power Supply Receiver	2
11	LVCMOSI/O	SCL	2-wire serial interface clock	
12	LVCMOSI/O	SDA	2-wire serial interface data	
13		GND	Ground	1
14	CML-O	Rx3p	Receiver Non-Inverted Data Output	
15	CML-O	Rx3n	Receiver Inverted Data Output	
16		GND	Ground	1
17	CML-O	Rx1p	Receiver Non-Inverted Data Output	
18	CML-O	Rx1n	Receiver Inverted Data Output	

19		GND	Ground	1
20		GND	Ground	1
21	CML-O	Rx2n	Receiver Inverted Data Output	
22	CML-O	Rx2p	Receiver Non-Inverted Data Output	
23		GND	Ground	1
24	CML-O	Rx4n	Receiver Inverted Data Output	
25	CML-O	Rx4p	Receiver Non-Inverted Data Output	
26		GND	Ground	1
27	LVTTL-O	ModPrsL	Module Present	
28	LVTTL-O	IntL	Interrupt	
29		Vcc Tx	+3.3V Power supply transmitter	2
30		Vcc1	+3.3V Power supply	2
31	LVTTL-I	LPMODE	Low Power Mode	
32		GND	Ground	1
33	CML-I	Tx3p	Transmitter Non-Inverted Data Input	
34	CML-I	Tx3n	Transmitter Inverted Data Input	
35		GND	Ground	1
36	CML-I	Tx1p	Transmitter Non-Inverted Data Input	
37	CML-I	Tx1n	Transmitter Inverted Data Input	
38		GND	Ground	1

Note 1: GND is the symbol for signal and supply (power) common for the QSFP+ module. All are common within the QSFP+ module and all module voltages are referenced to this potential unless otherwise noted. Connect these directly to the host board signal-common ground plane.

Note 2: Vcc Rx, Vcc1 and Vcc Tx are the receiver and transmitter power supplies and shall be applied concurrently. Requirements defined for the host side of the Host Edge Card Connector are listed in Table 6. Recommended host board power supply filtering is shown in Figure 4. Vcc Rx Vcc1 and Vcc Tx may be internally connected within the QSFP+ Module module in any combination. The connector pins are each rated for a maximum current of 500 mA.

SFP+ Pin Descriptions

Pin	Logic	Symbol	Name/Description	Notes
1		VeeT	Transmitter Ground	
2	LV-TTL-O	TX_Fault	N/A	1
3	LV-TTL-I	TX_DIS	Transmitter Disable	2
4	LV-TTL-I/O	SDA	Tow Wire Serial Data	
5	LV-TTL-I	SCL	Tow Wire Serial Clock	
6		MOD_DEF0	Module present, connect to VeeT	
7	LV-TTL-I	RS0	N/A	1
8	LV-TTL-O	LOS	LOS of Signal	2
9	LV-TTL-I	RS1	N/A	1
10		VeeR	Receiver Ground	
11		VeeR	Receiver Ground	

12	CML-O	RD-	Reciever Data Inverted	
13	CML-O	RD+	Reciever Data Non-Inverted	
14		VeeR	Reciever Ground	
15		VccR	Reciever Supply 3.3V	
16		VccT	Transmitter Supply 3.3V	
17		VeeT	Transmitter Ground	
18	CML-I	TD+	Transmitter Data Non-Inverted	
19	CML_I	TD-	Transmitter Data Inverted	
20		VeeT	Transmitter Ground	

1. Signals not supported in SFP+ Copper pulled-down to VeeT with 30K ohms resistor
2. Passive cable assemblies do not support LOS and TX_DIS

Ordering information

Part Number	Product Description
QSFP-4SFP10-01C	QSFP+ To 4X SFP+ Direct Attach Cable, 1m (30AWG), 0°C ~ +70°C
QSFP-4SFP10-03C	QSFP+ To 4X SFP+ Direct Attach Cable, 3m (30AWG), 0°C ~ +70°C
QSFP-4SFP10-05C	QSFP+ To 4X SFP+ Direct Attach Cable, 5m (28AWG), 0°C ~ +70°C

E-mail: sales@robofiber.com